



polar



**- A TECHNOLOGICAL
FRONTRUNNER FOR
DEMANDING USERS**

**WE MADE SISU,
A TRUCK
WE ARE
PROUD
OF**



polar

**DESIGNED
FOR
EXTREME
CONDITIONS**

The Sisu Polar series offers superiority in a single package: the customer receives a customised vehicle featuring top-of-the-range technology. Since the truck is fully-equipped at the factory, it is ready for use as soon as it leaves the factory gates. Sisu Polar combines our wide range of experience in heavy-duty transportation equipment with advanced technological solutions.

The Sisu Polar is cost effective since all components are installed in place at the factory, meaning it is ready for use as soon as it exits the premises. For the customer, there is no need for retrofitting. Tailored manufacturing means a shorter delivery time, certainty that the chassis and superstructure will be seamlessly compatible and optimal dimensioning of payload and strength. We use the best components to manufacture our vehicles. This ensures that the customer gets a durable vehicle with a long service life. It also retains its value.

Customer-oriented design, flexibility and a quick delivery are all key features in our operations. Our team designs the vehicle based on the planned end use for the vehicle. Customer needs are taken into account right from the start of the design process. Even though we customise our products, we do not compromise on delivery times.



MAIN COMPONENTS



CABIN

The cabin package is supplied by Daimler AG and modified in Finland.



ENGINE

You can choose a power source from several high quality Mercedes Benz engines.

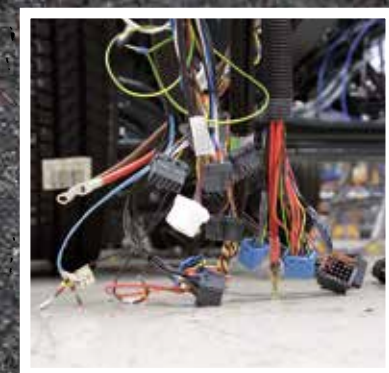

BASIC SYSTEMS

The electrical system is based on the Mercedes Benz technology and electronics, to which we've added additional functions and equipment required by challenging arctic conditions. Cooperation with Daimler AG means top products for Sisu's truck technology and complete compatibility between the engine and additional equipment.



TRANSMISSION

Automated transmissions:
Mercedes Benz PowerShift G280-16
Mercedes Benz Telligent G240-16 Synchron

Manual transmission:
Eaton Fuller RTLO 20918 B



DESIGN AND MANUFACTURE FOR EXTREME CONDITIONS

Sisu Polar contains many unique features that cannot be found elsewhere. Thanks to our extensive experience, the vehicles are made to last and remain operational even in demanding conditions. A sturdy frame, strong low-end torque and high-quality transmission ensure reliability, even in difficult spots. An optimal payload and low fuel consumption make for an economical drive. In this way, the strain placed on the environment is also reduced, which is an increasingly significant issue.

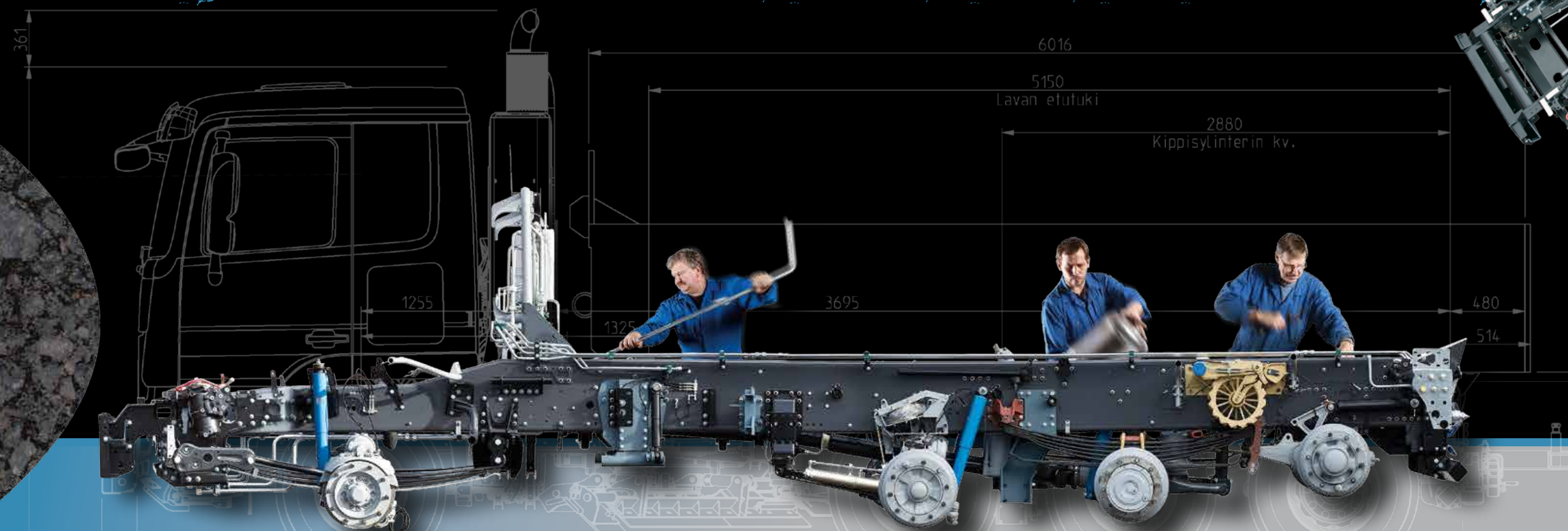

THE SISU POLAR ORDER AND PRODUCTION PROCESS > LIST THE FEATURES AND EQUIPMENT YOU WANT IN YOUR NEW VEHICLE > YOU WILL RECEIVE A TAILORED, READY-TO-USE SISU POLAR, WHICH CAN ALSO BE REGISTERED AT THE FACTORY IF NEEDED.



- 1 SELECTION OF END USE AND EQUIPMENT
- 2 OFFER AND 3D DESIGN
- 3 CUSTOMER ORDER
- 4 FACTORY MATERIAL AND STRUCTURE LISTING
- 5 CUSTOMER DESIGN AND PRODUCTION PLAN
- 6 PRODUCTION
- 7 FINISHING AND DOCUMENTATION - INCLUDING SUPERSTRUCTURES
- 8 DELIVERY OF READY-TO-USE VEHICLE

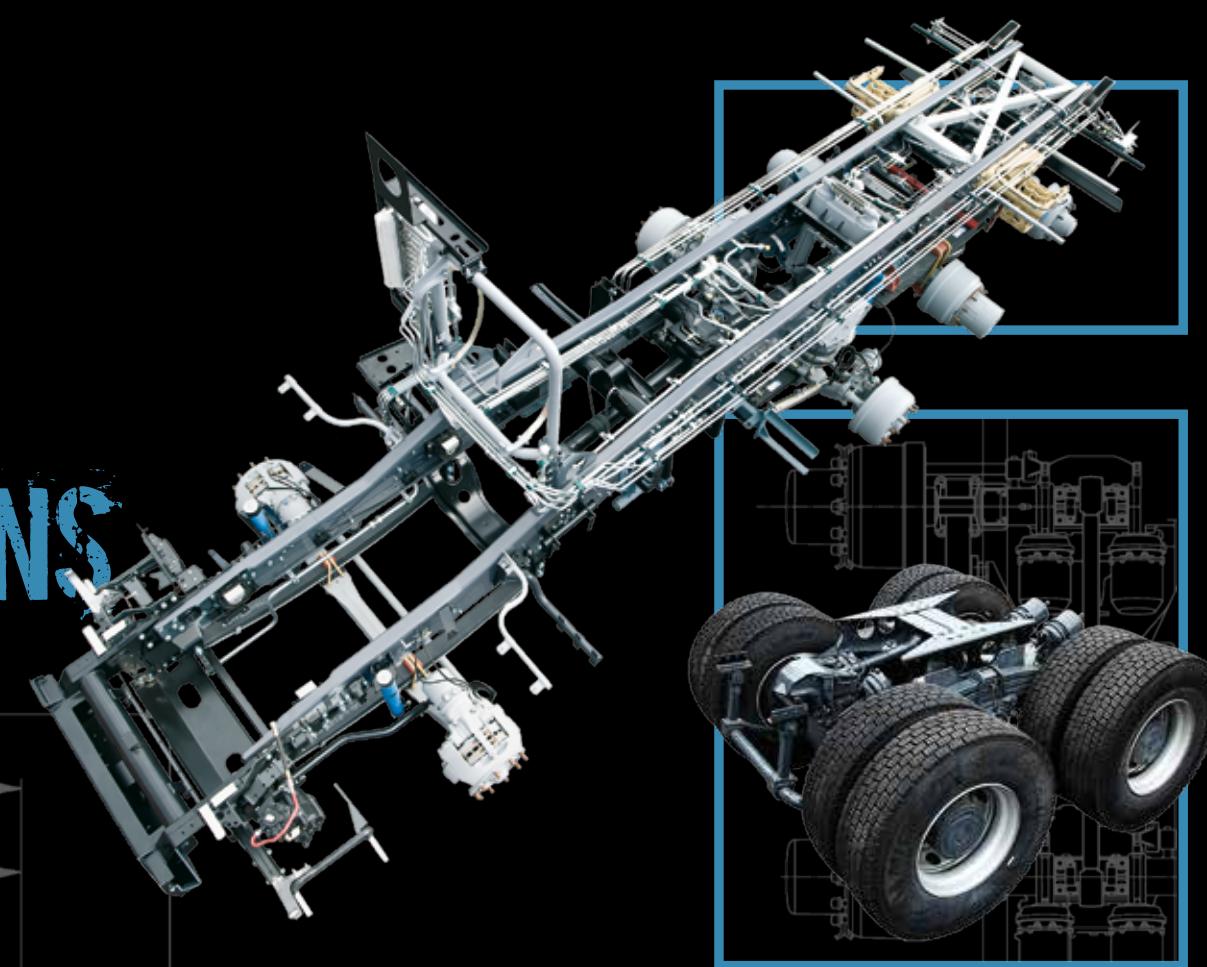

FRAME

Each Sisu Polar frame is designed and manufactured with the vehicle's end purpose in mind. A good, sturdy and finished frame ensures a long service life and high resale value, which increases profitability.

SUSPENSION AND AXLES

The axles which drive Sisu Polar are designed and manufactured for heavy use and arctic conditions. Sisu Polar can be equipped with a bogie drive or bogie lift, each providing their own advantages depending on use. Due to its lighter structure, a bogie lift allows for a larger payload and is therefore an economical option for the customer. The rearmost axle on the bogie drive can be raised and disconnected from the drive, which improves the vehicle's mobility. It is the only bogie drive on the market that allows this.



PURPOSE-SPECIFIC EQUIPMENT

Sisu Polar is a carefully designed, optimised package in which the vehicle's superstructure and chassis fit together seamlessly. The factory warranty we issue for a ready factory delivery demonstrates our clear responsibility in warranty issues.

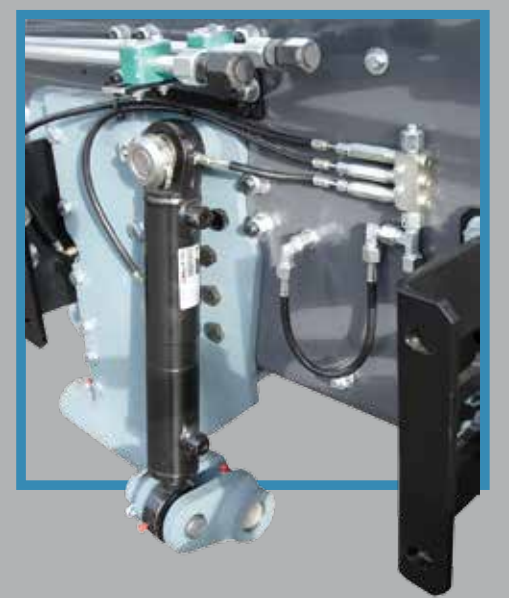

PURPOSE-SPECIFIC SYSTEMS

Sisu Polar contains a clear, easy-to-use equipment control system which can be expanded depending on the task at hand.





THE ONLY
HEAVY-DUTY
VEHICLE SERIES
ON THE MARKET
YOU CAN DRIVE
STRAIGHT FROM
THE FACTORY TO
WORK

Subject to change without prior notice. SISU Polar GB 1/2013



DESIGNED AND MANUFACTURED
IN EXTREME CONDITIONS AND TAILORED
FOR THE TRUE PROFESSIONAL.

Oy Sisu Auto Ab
Tammisaarentie 45
Karjaa, Finland
Puh. +358 10 2751
fax +358 19 236 044

www.sisuauto.com